

Option

Counter Display:

This counter display allows the customer to easily view counter totals.



Interface:

Interface for connecting the bank note counter to a computer terminal or other device with an RS232C interface.

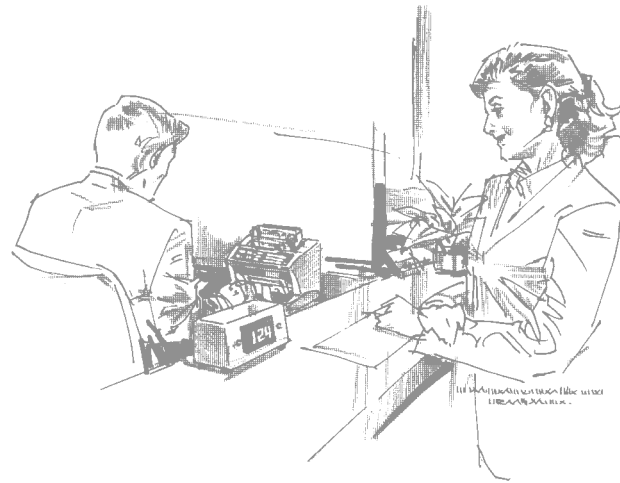
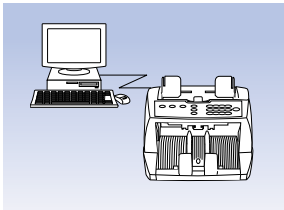

Specifications

Dimensions	275 (W) x 235 (H) x 230 (D) mm (10.827" x 9.252" x 9.055")
Weight	5.5 kg – 6.0 kg (12.125 lbs – 13.227 lbs)
Countable note size	50 x 85 mm – 110 x 185 mm (1.969" x 3.346" – 4.330" x 7.283") Thickness: 0.06 x 0.12 mm (0.039" x 0.004")
Counting speed	1800, 1500, 1000, 500 notes/min. (four step system)
Feed system	Roller friction system
Hopper capacity	300 sheets
Stacker capacity	200 sheets
Counting display	4-digit LED (large)
Batch display	3-digit LED (small)
Power supply	AC100 – 240V 50/60Hz
Power consumption	1.2A (100 – 127V), 0.6A (220 – 240V)
Buzzer	Gives an alarm when a different denomination is detected.

Dimensions

Weight: 5.5—6.0 kg
(12.125—13.227 lbs)

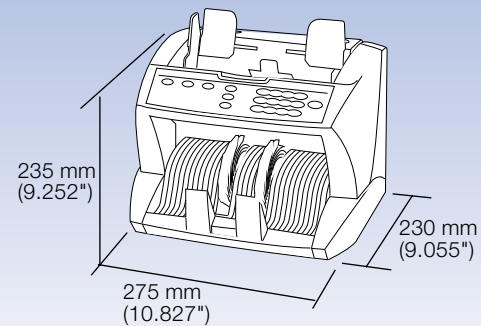

GLORY[®]
Quality the World Counts on

*Specifications are subject to change without notice.
*Copyright (c) 2001 by Glory Shoji Co., Ltd. All rights reserved.

Distributed by:

GLORY[®]

Desktop
Bank Note Counter
GFB-800/900 Series



- High-quality, High-performance, High-reliability
- A full line of bank note counters that meet a wide range of customer needs.
- MCCD system protects against counterfeiting

The GLORY Brand— Products of Exceptional Reliability

Glory products are constructed using original Glory-brand parts that have been manufactured with Glory's own original technologies since 1918. Our products are a culmination of the effort, experience and



know-how we have developed and fostered over our many years in business. It is with great pride and assurance that we provide products offering the best in quality, functionality, operability and durability. Our customers can be assured of years of reliable service from our products. The exceptional performance of our products raises the bar on the quality and efficiency of bank note counting and identification operations.



Excellent solutions for bank note counting and identification needs

All of the MCCDs (Multiple Currency Counterfeit Detector) used in our bank note counters have been developed by Glory

Although many of these outstanding technologies lie deep inside our devices, where they are not readily visible, be assured that each GFB is supported by an abundance of advanced Glory technologies.



Ultra Violet Detection Sensor



Magnetic Ink Detection Sensor



Metal Detection Sensor



Infrared Ink Detection Sensor



Four types of MCCDs, all developed by Glory

The MCCDs can be used in a wide range of combinations for compatibility with the various bank notes of countries around the world.

Today's bank note counters must be able to deal with the new Euro, US dollars, and the various bank notes of countries around the world. We are also seeing an increase in the appearance and distribution of counterfeit bank notes as a result of more advanced and diverse

counterfeiting technologies, primarily, the advancement and spread of digital copying and printing technologies.

With the GFB-800/900 as the base unit, a GFB can be equipped with up to four types of MCCDs for compatibility with the numerous shapes and characteristics of the bank notes from countries and regions around the world.

With the "CF Auto Mode" function, the GFB identifies the

specific characteristics of the bank notes being counted, then automatically turns on each MCCD sensor as needed.

•This applies only to models equipped with multiple MCCD sensors.

		800 Series	900 Series
DD	Width	•••••	•••••
	Length		•••••
	UV	•••••	•••••
	MG	•••••	•••••
	MT	•••••	•••••
	IR		•••••

Desk-top Bank Note Counter

GFB-800/900

Speed and efficiency that contribute to smooth business operations

Glory GFBs achieve a high counting speed of 1800 notes per minute, the fastest in the world for a device in this class. Glory's acclaimed technologies overcome the possibility of increased error and miss-count rates that often accompany increased speed, making it possible to achieve a counting speed unmatched by conventional counters. Glory GFBs can also be set to counting speeds of 1500, 1000 and 500 notes per minute.

Batch operations—Fast, efficient bank note bundling

Glory GFBs are equipped with automatic batch functions, and preset keys can be used to quickly select



batch sizes of 10, 20, 25, 50 and 100 notes. The counter's numeric keypad can also be used to manually set the batch capacity from 1 to 999.

Easy to master functions, speedy operation

- Easy to see, easy to understand display panel. Fast, easy operation using the numeric keypad.
- Simply select Auto-Start or Manual-Start.
- Auto-Start: Bank notes are placed in the counter's hopper, note counting begins automatically and the notes are simultaneously checked for authenticity.
- When counted or bundled notes are removed from the stacker, the note counter automatically resets itself for the next operation.



One counter per shop. One counter per sales counter. One counter per person

Glory GFBs are an indispensable addition to any facility where bank notes need to be counted or checked for authenticity.

For example—financial institutions (banks, stock brokerage firms, currency exchangers), casinos, gambling facilities, racetracks, distribution facilities (department stores, supermarkets, retail shops), transportation facilities (train stations, bus terminals, taxi headquarters), airports, hotels, theaters, leisure and amusement facilities, game arcades, event halls, etc.

